

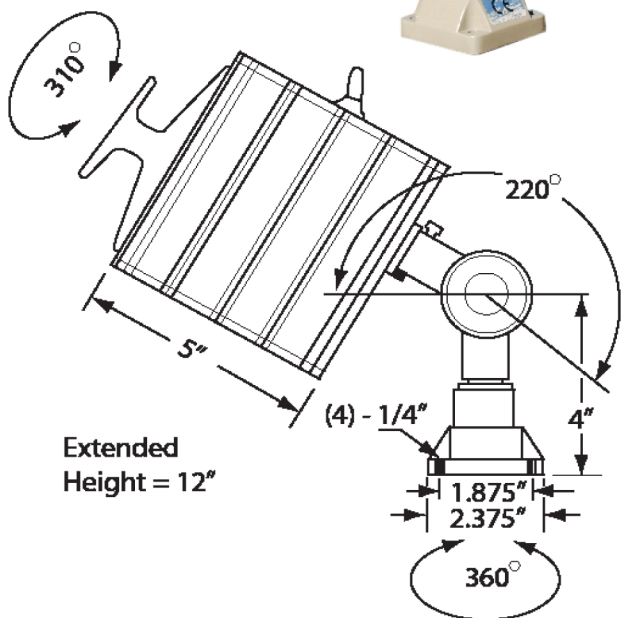

Technical Specifications



Safety Certifications	
CE Mark of Declaration	
Waterproof Certification	
IP 65 (Waterproof)	
Dimensions	
• Height	8.25"
• Diameter	5.00"
• Base Dimensions	2.375" X 2.375", .25" flanged corners with 5mm mounting holes
• Beam	310°
• Net Weight	4 lbs
Material Specifications	
• Metal	Anodized aluminum
• Gaskets	Neoprene polymer located at head and switch
• Lens	Tempered borosilicate glass
Electrical Specifications	
• Voltage	12 volts direct current
• Cycle	N/A
• Transformer	N/A
• Amperage	4.17
• Wattage	50
• Kelvin (color temperature)	4100
• On/off switch	Toggle located on light head's back plate
Cord Specifications	
• Certification	SJT (oil resistant)
• Length	70.0"
• Plug	N/A, wires directly into power source of choice
• Composition	14 gauge 2-conductor copper wiring, SJT (oil resistant) certified neoprene jacket
Options	
• Lens	Thick curved lens
• Mounting Brackets	HLP-22-2000 (see below) HLP-23 (see below) HLP-30 (see below)
• Bulbs	HLP-70-H3-24, HLP-75-BI-24, HLP-100-BI-24



Products specifications are subject to change.

